

ALL FABRICATION FILES, ASSEMBLY FILES, AND SUPPORT DOCUMENTATION (INCLUDING PERTINENT DESIGN DOCUMENTS) ARE MAINTAINED ON EDGE.RIT.EDU UNDER PROJECT NUMBER P13321 - LEVITATION CLOCK

FEATURE	DESCRIPTION
OVERALL THICKNESS	0.063 in.
SURFACE COPPER THICKNESS	1 oz. minimum
FLAME RESISTANT	FR4 170TG/290TD
PCB LAYERS	2 sides

- 1.0 FABRICATE BOARD PER IPC-A-600 PRODUCT CLASS 1
- 2.0 THIS IS A TWO LAYER PCB, SHOWN FROM THE MANUFACTURING LAYER SIDE 1.
- 3.0 DIMENSIONING AND TOLERANCING PER IPC-2615
- 4.0 BOARD FINISH PER IPC-4552
- 5.0 EACH PCB SHALL BE ELECTRICALLY TESTED AS PER P13321-DOC-TESTW
- 6.0 SOLDERMASK BOTH SIDES. MUST BE "LEAD-FREE PROCESS COMPATIBLE"
- 7.0 MARKINGS: WHITE SILKSCREEN APPLIED TO ONE OR BOTH SIDES OF PCB. MUST BE "LEAD-FREE PROCESS COMPATIBLE"

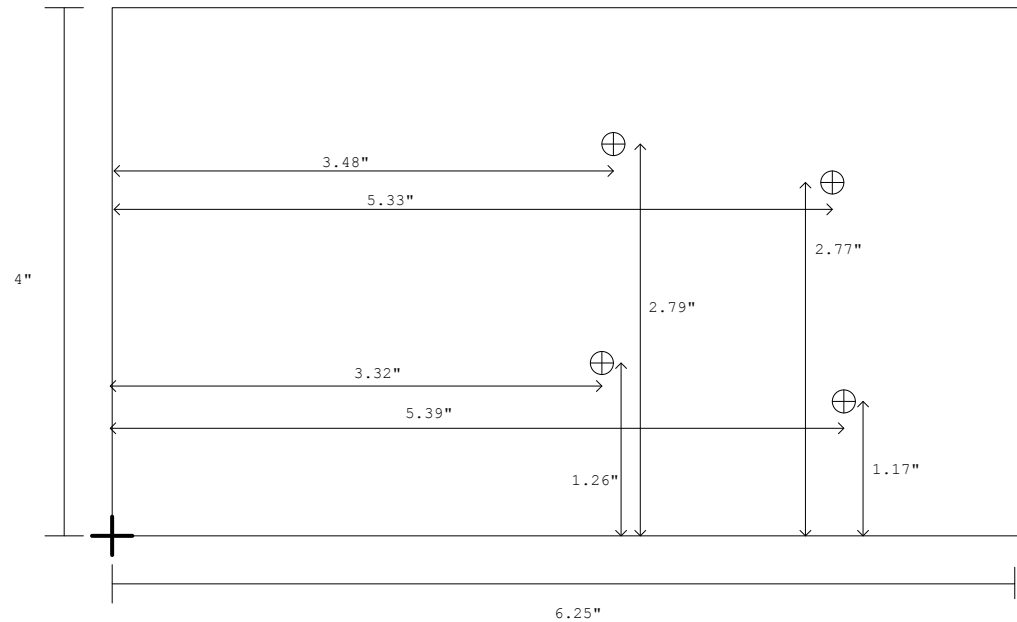

Main Controller Bare Board - P13321-PCB-MPCBA

Author: Kevin Fronczak

REV: 2